



Manual

SIR-9151-UE

Product name
SIR-9151-UE
Last Change
09.05.2022

Version
1.0
Author
B. Bröhl

Document revision
0.1

(c) scemtec Transponder GmbH 2015

Contents

1	General.....	4
1.1	Care and maintenance.....	4
1.2	RFID systems.....	5
1.3	RoHS and WEEE directives.....	5
1.3.1	RoHS.....	5
1.3.2	WEEE (Waste Electrical and Electronic Equipment).....	6
2	Safety informations.....	7
3	System description.....	8
4	Getting started.....	9
4.1	Connection via USB and external power supply.....	9
4.2	Mounting.....	9
5	Basic configuration.....	11
5.1	Configuration with SMan.....	11
5.2	<i>Configuration via web interface.....</i>	<i>12</i>
6	Operating modes.....	14
6.1	Host mode.....	14
6.2	Default (Stand alone) mode (SmartRead).....	14
7	Software.....	15
7.1	Software utilities.....	15
7.2	Firmware.....	15
7.3	STX/ETX interface protocol.....	15
7.4	Configuration/Web interface.....	15
8	Hardware.....	17
8.1	Voltage supply.....	17
8.2	Interfaces.....	17
8.2.1	USB.....	17
8.2.2	RS232.....	17
8.2.3	Ethernet.....	17
8.3	Diagnosis LEDs.....	18
8.4	Memory.....	18
9	Specification.....	19
9.1	Electrical specification.....	19
9.2	RF power steps.....	19
9.3	Dimensions.....	20
10	Optional accessories.....	20
10.1	Power supply/Connecting-cables.....	20
11	Related documents.....	21
12	Contact sttID.....	22
13	Document history.....	23

1 General

scemtec Transponder Technology GmbH (*sttID*) reserves the right to make changes or to discontinue its products or services at any time without notice.

sttID takes no responsibility for customer applications, products, or performance relating to systems or applications incorporating with *sttID* products.

sttID assumes no liability and is not responsible for infringement of patents and/or any other intellectual or industrial property rights of third parties, which may result from assistance provided by *sttID*.

All other products mentioned in this document might be brands or brand names of the different suppliers.

1.1 Care and maintenance

- Care has to be taken, that the Reader and/or the attached antenna is not exposed to any electrostatic discharge (ESD). Electrostatic discharge may cause serious damage to the Reader. It is strongly recommended, that sufficient ESD protection is applied in critical environment.
- Keep the device dry. Humidity and liquids contain minerals will corrode electronic circuits and tarnish transparent plastic parts. The device is not waterproof and should not be exposed to rain or moisture. Under extreme conditions, water may enter the circuitry.
- Avoid mechanical shocks. Handle the device with care. Shocks may break internal circuit boards.
- Take care not to scratch the device. Keep the device clean. When working with the device, use only *sttID*-approved accessories.
- Do not store or use the device in any location that is extremely dusty, dirty, damp or wet.
- Do not store in hot areas. High temperatures can shorten the life of electronic devices, damage batteries and warp or melt certain plastics. Protect the device from extreme temperatures. For example, do not place the device in a windowed area where the sun may cause extreme temperatures, and keep it away from heaters and other heat sources.
- Do not store in cold areas. When the device warms up (to its normal temperature), moisture can form inside the device, which may damage electronic circuit boards.
- Do not attempt to open the device during operation, outside installation and maintenance periods. Non-professional handling of the device may damage it.
- Do not paint the device. Paint prevent proper operation. Paint with metallic contents may limit device performances.
- If the device or any accessory are not working properly, take it to your nearest *sttID*-Partner.

1.2 *RFID systems*

As this technology is based on radio frequency, one must exercise the following operational and mounting instructions to achieve best performance:

- Metal affects radio signals. Normally the antenna has to be as far away as possible from any metal object and it's damping influence on the magnetic field. Only this leads to the best distribution of the magnetic field in the reading range. Very important as well is not to have "short circuits", in the vicinity of the antenna, damping the magnetic field. A "short circuit" is any metal near the antenna, building a "metallic ring", so that currents introduced by the RF-field can flow, absorbing the energy needed for the tag to operate.
- Care must be taken to reduce or eliminate unwanted signals (so called interference or noise) from external sources. The reading range may be reduced by following noise sources:
 - portable two way radio
 - cellular phones
 - switching power supplies
 - computer monitors
 - frequency converters (e.g. motor control systems)

Generally all cabling should be placed in sufficient distance from every potential noise source. However, in case of any problems additional noise suppression may be necessary (e.g. ferrites on cables). If needed, don't hesitate to contact *sttID* for additional installation guidance.

- The read range is depending upon
 - performance of the Reader
 - size of the antenna
 - size of the tag (the bigger the better)
 - orientation of the tag antenna plane to the Reader antenna plane
 - quality of the tag
 - matching of Reader antenna size and tag (-antenna) size
 - environmental, electrical noise
 - If influence of metal can not be fully avoided a tuning of the antenna is required and will improve reading range

1.3 *RoHS and WEEE directives*

1.3.1 *RoHS*

sttID certifies that this product is compliant with the European Directive 2011/65/EU (RoHS II) for the restriction in Electrical and Electronic Equipment's (RoHS) of the use of the following hazardous substances:

- Cadmium
- Hexavalent Chromium

- Lead
- Polybrominated biphenyl flame retardants
- Polybrominated diphenyl ether flame retardants
- Mercury

This declaration is based on information provided by our suppliers and subcontractors.

1.3.2 WEEE (Waste Electrical and Electronic Equipment)



This product bears the selective sorting symbol for waste electrical and electronic equipment (WEEE). This means that this product must be handled pursuant to European Directive 2011/65/EU in order to be recycled or dismantled to minimize its impact on the environment. For further information, please contact your local or regional authorities.

2 Safety informations

As with all electronic systems, the system described hereafter may not be used for any applications critical for maintaining safety. This means, the products may not used in life support applications or any other life critical applications that could involve potential risk of death, personal injury or severe property or environmental damage.

The user/operator is solely responsible for any damages resulting from an improper or unintended utilization of the system.

3 System description

This manual describes the UHF Reader System SIR-9151-UE, hereafter referred to as “Reader”.

The Reader is designed to be used as compact desktop device.

The SIR-9151-UE is designed as a multi-tag system for reading and writing information stored on UHF transponders (TAGs). The Reader permits a reading range up to 1 meter depending on power step and transponder type and size.

Transfer of data between the Reader and a host computer is possible via USB, asynchronous RS232 and Ethernet interface. By default the Reader is configured for “stand-alone” operation using the implemented SmartRead feature.

The Reader is compatible EPC Class1 Gen. 2 UHF transponders(acc. to ISO/IEC 18000-6c).

4 Getting started

The SIR-9151-UE has to be connected to a power-supply as recommended in the chapter 8.1. Communication can be done via one of the interfaces (USB, RS232 or Ethernet).

4.1 Connection via USB and external power supply

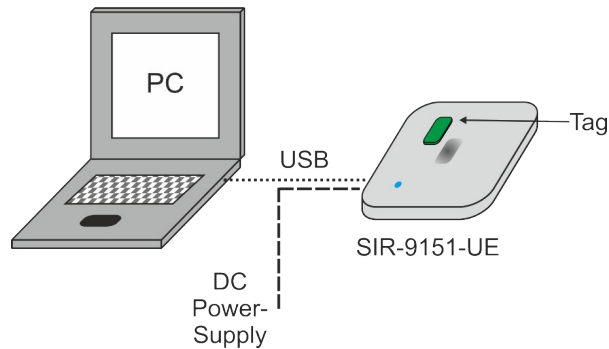

Since the reader is preconfigured for stand alone mode, after connecting SIR-9151-UE like shown above it starts reading UHF transponders. Recognized EPC Codes are transferred via the USB interface and can be received on a PC, e. g. using a simple terminal program.

Alternatively one can use a *sttID* demonstration-software like “SimpleDemo” or “UniDemo” to control the Reader in host mode. For more details please refer to “Quick Start Guide read”. This guide is available for download on www.stt-rfid.com.

4.2 Mounting

When mounting the Reader on a wall or under a table, only the provided screw-holes has to be used. Fixing to the wall/table has to be done with appropriate installation material (not included) using all of the foreseen mounting points.

For safety reasons the Reader must not be installed more than 2 m above the ground.

When installing the Reader, please make sure that the maximum ambient temperature is not exceeded at any time. Therefore the Reader should only be installed in places where sufficient ventilation is assured. Any kind of possible heat accumulation should be avoided (e.g. the Reader should not be mounted in an additional housing or cabinet).

The SIR-9151-UE is primarily designed as desktop device. Nevertheless it also can be mounted to a wall or e. g. beneath a table.



For mounting the reader, remove the cover from all feet and remove the screws (T15 Torx). The screw holes can be used to drill assembly holes (diameter ≤ 5 mm) and fixing the SIR-9151-UE with longer screws on a wall or below the table.

Attention: Care has to be taken, that the Reader is not exposed to any electrostatic discharge. That is why anti-static material is to prefer for the mounting construction.

5 Basic configuration

For basic configuration it is recommended to use SMan.

It is strongly recommended to remove all tags from the antenna area to avoid communication errors!

Start SMan and select your SIR-9151-UE device and click 'Connect'.

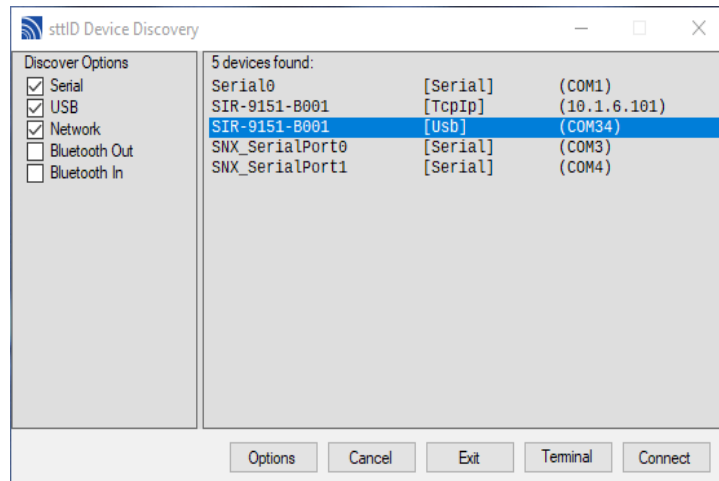

If Ethernet is chosen as interface, SMan will suggest to use the integrated web interface for configuration, since using a browser may be more convenient.

5.1 Configuration with SMan

If the SIR-9151-UE is connected to USB or RS232, SMan can be used to do complete configuration.

Choose menu *Device* → *Interface Settings*.

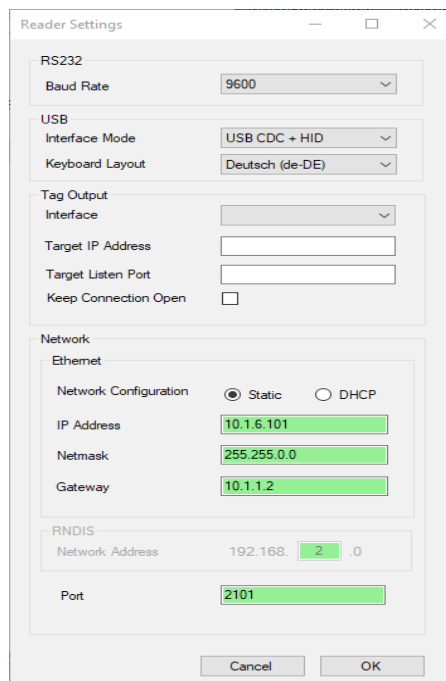

Pressing 'OK' will save the settings and restart the Reader.

SmartRead configuration

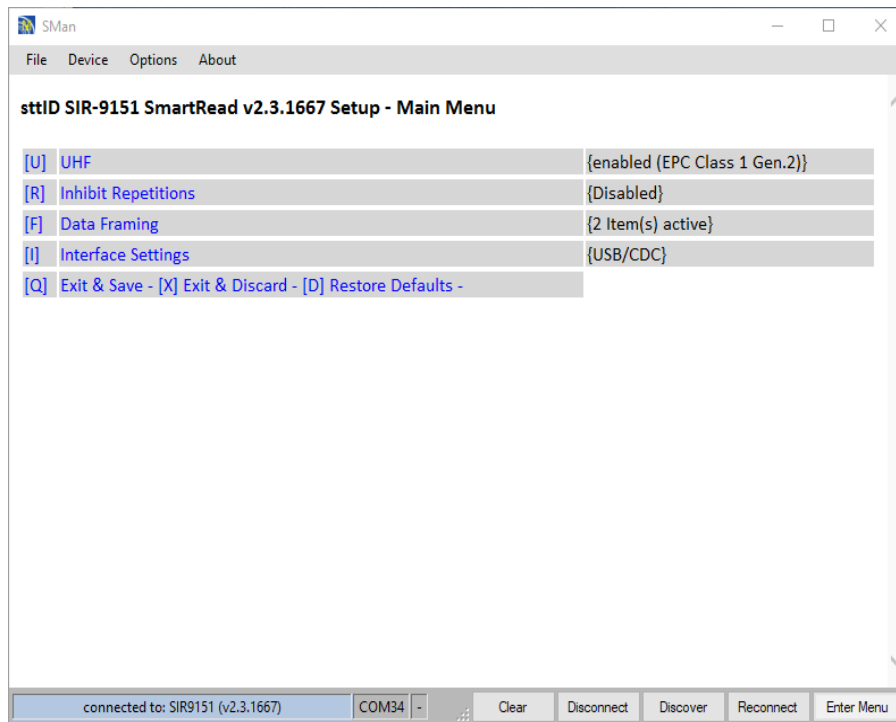

SmartRead configuration menu can be reached by pressing 'Enter Menu'.

5.2 Configuration via web interface

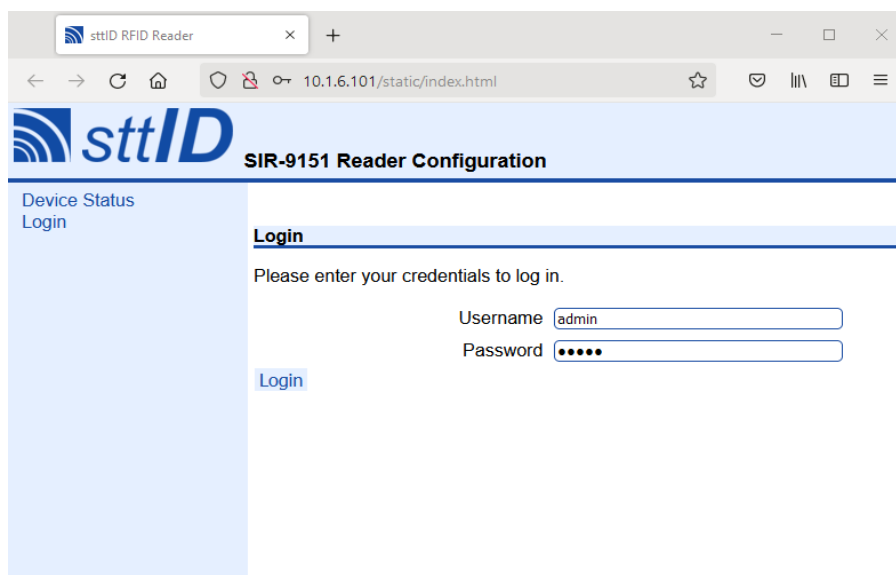

Default login credentials:

Username: admin

Password: admin

Interface configuration

Configuration of interfaces is not part of SmartRead configuration and can be done by configuration page.

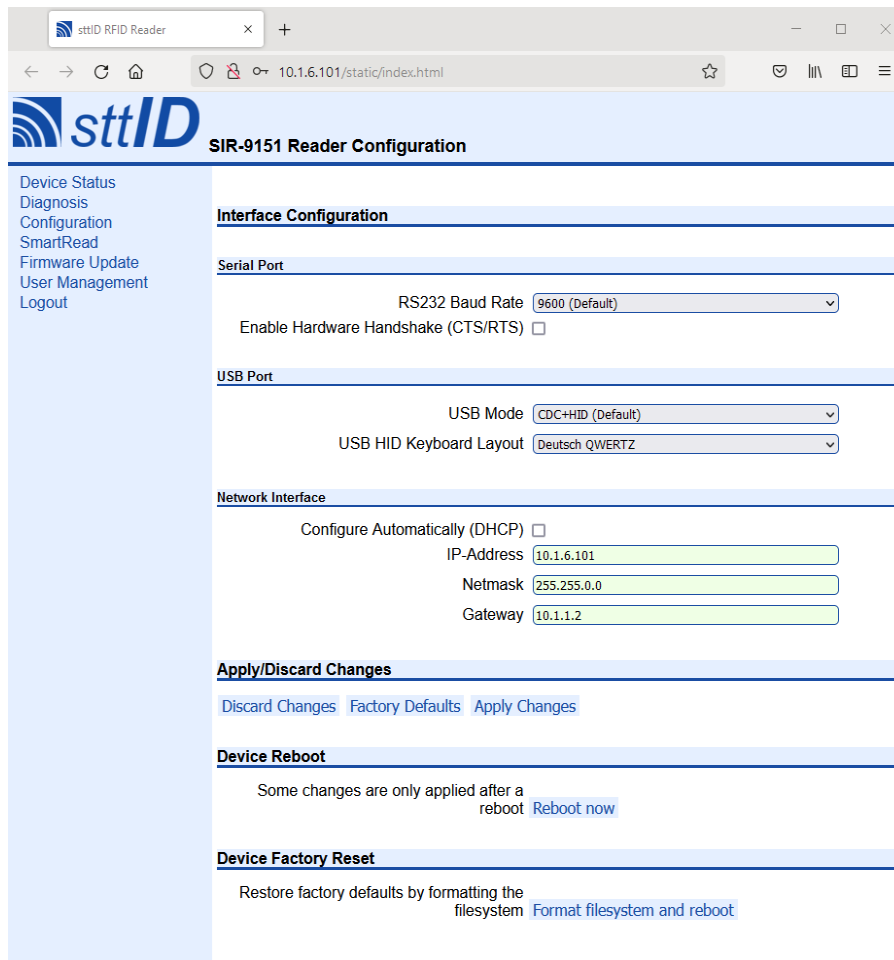

After changing configuration press 'Apply Changes' to save all modifications.

6 Operating modes

6.1 *Host mode*

In Host mode the Reader is completely controlled by a Host system connected to one of the available interfaces via STX/ETX commands. For further information, please refer to the STX/ETX protocol description in chapter 7.3.

6.2 *Default (Stand alone) mode (SmartRead)*

By default the Reader is configured in stand alone mode by use of the “SmartRead” feature. Default configuration provides reading of EPC Code of UHF EPC Class1 Gen.2 transponders. Data is transferred via the USB interface in CDC mode.

For further Information about SmartRead please refer to the correspondent SmartRead-manual, which can be downloaded from www.stt-rfid.com.

7 Software

7.1 *Software utilities*

Various software utilities for Windows for the Reader are available for download on www.stt-rfid.com. Linux Versions are available on request.

Available Software utilities:

- SimpleDemo
 - Demo Software for easily controlling the Reader with a Host system.
- UniDemo:
 - Universal Demo Software for extended controlling the Reader with a Host system.
- STXTerm:
 - Terminal program for controlling the Reader with a Host system by directly submitting STX/ETX commands. For submitting multiple STX/ETX commands a comprehensive Script utility is implemented.
- Flasher:
 - Utility for updating firmware on the incorporated Microprocessor
- SMan or SmartManager:
 - Utility for configuration and using the Reader in Stand alone mode (SmartRead).
- scemtec STX/ETX .NET Library

7.2 *Firmware*

The firmware of the Reader provides all basic functions for reading and writing tags of different manufacturers (air protocol), numerous control and configuration functions, as well as different diagnosis routines.

Firmware can be updated by the user via USB or RS232 Interface using flasher tool. Furthermore updates can also be performed via Ethernet using the integrated web interface. The latest firmware files are available for download on www.stt-rfid.com.

7.3 *STX/ETX interface protocol*

For communication between Reader and a host system *sttIDs* STX/ETX protocol is used. The required STX/ETX protocol description can be downloaded from www.stt-rfid.com.

A list of supported STX/ETX commands can be read out from the Reader via the STX/ETX command '100E' or via STX/ETX script 'Get Fn List.stx' (which will be installed together STXTerm software).

7.4 *Configuration/Web interface*

All configurations can be done using STX/ETX command or SmartRead configuration tools respectively.

However, most configurations as well as firmware updates can also be done via an integrated web interface in a more comfortable way. Therefore enter the readers IP address in

your preferred browser. Determine the readers IP address can be done with SimpleDemo or SMan.

For changing any configuration one have to login first.

Default login credentials:

Username: admin

Password: admin

It is recommended to change the password after first login.

Note: Web interface is only available with Firmware 2.0 or higher.

8 Hardware

8.1 Voltage supply

The SIR-9151-UE is designed for a 12 V DC voltage supply connectible via a standard 2.1 mm barrel connector.

Polarity of connector	
-----------------------	---

The Reader may only be connected to a power supply with a minimum output current of 1 A, which is tested for safety according to appropriate standard (e. g. EN60950).

A suitable wall plug power supply is available as optional accessory. For best performance and safety, *sttID* strongly recommends to use only this power supply.

The power supply is intended to be used only with connection cables not longer than 3m.

8.2 Interfaces

The SIR-9151-UE provides USB, RS232 and Ethernet communication interfaces.

The interfaces are intended to be used only with connection cables not longer than 3m.

8.2.1 USB

The Reader is equipped with a USB 2.0 full speed (12 Mbits/sec) port. The connection is made via a standard USB-B connector.

Supported profiles	CDC-ACM (virtual COM-Port), HID (Keyboard emulation)
--------------------	--

Appropriate drivers for Windows are available for download on www.stt-rfid.com.

8.2.2 RS232

The Reader is equipped with a RS232 interface. The connection is made via a 3 pole multi-pin connector compatible with Phoenix FMC 1,5/3-ST-3,5 and Würth WR-TBL (691 3041 00003). Connector pins counted from top view pin1 at left to pin 3 at right:

Terminal designation	Connector Pin	Terminal Function
TxD	1 (left)	Transmit Data
RxD	2 (middle)	Receive Data
GND	3 (right)	Ground

The data transfer rate is adjustable via STX/ETX commands.

Configuration	8 Data Bits, 1 Stop Bit, no Parity, no flow control
Supported Data Rates [baud]	1200, 2400, 4800, 9600 (default), 19200, 38400 57600, 115200, 230400

8.2.3 Ethernet

The Reader is equipped with a 10/100 T-Ethernet interface.

By default the Reader gets its IP Address via DHCP.

Nevertheless the Reader can also be configured with a static IP Address.

Network settings can be configured with SMan, SimpleDemo or if available via Web-Interface. In addition it can be configured by using STX/ETX commands. For details please refer to STX/ETX protocol description.

8.3 *Diagnosis LEDs*

An RGB-LED provides diagnosis of the most important monitoring functions.

Priority	Description	Color
1	Error	red
2	Tag detect. A read or write process for the transponders has concluded successfully. (In host mode not functional)	yellow
3	SmartRead active	flashing
4	USB CDC connection active	blue
5	Network connection active	blue
6	Network waiting for IP Address	blue blinking
7	IDLE	green

8.4 *Memory*

The SIR-9151-UE has an internal volatile storage for buffering an inventory of maximum up to 100 tags by a maximum EPC length of 128 bit. Note that the storage is in stand alone mode also used to store the tags for the suppress function.

9 Specification

9.1 Electrical specification

Electrical specification (Ambient temperature: 25°C)						
Parameter	Test condition	Symbol	Min.	Typ.	Max.	Unit
DC input voltage	—	V_{in}	10	12	28	V
Current consumption	Read @ max. power $V_{IN} = 12\text{ V}$	I_{in}	—	—	250	mA
Current consumption	Idle - mode $V_{IN} = 12\text{ V}$	I_{in}	—	—	150	mA
Operating frequency	—	f_{UHF}	865.7	—	867.5	MHz
RF power (internal)	power step = 15 attenuator off	$P_{internal}$	-1 dB	400	+1 dB	mW
Operating (ambient) temperature range	—	T_{amb}	0	—	50	°C
Storage temperature range	—	T_{stg}	-10	—	50	°C

9.2 RF power steps

The RF power is adjustable in 15 steps for. For very low distance application an internal 6 dB attenuator is selectable for UHF unit in addition.

The below stated power values represents the values, that are generated by the correspondent internal power unit. Since the generated power is directly feed into the integrated antennas, these values are not measurable and therefore only have informational character.

Attention: National regulations regarding radiated power has to be considered, when setting the RF power. The user is solely responsible to observe legal restrictions for the radiated RF power.

Power step	UHF power internal [mW] (defined on nominal 50 Ohm load, typical values @ 20° C)	
	Attenuator disabled	Attenuator enabled
15	400	100
14	316	79
13	250	63
12	200	50
11	158	40
10	125	31
9	100	25
8	79	20
7	63	16
6	50	12
5	40	10

4	31	8
3	25	6
2	20	5
1	16	4

9.3 Dimensions

Dimensions	
Width	310 mm
Height	260 mm
Depth	28 mm without rubber pads 30.5 mm with rubber pads

Weight	
Without package	2000 g

Environment	
Temperature range	0 °C to + 50 °C
Protective systems	IP20 (indoor)

10 Optional accessories

10.1 Power supply/Connecting-cables

- Recommended 12 V DC/1000 mA power-supply adapter, cable length 1.3 m [order-no.: 999.1280]
- USB cable A plug to B plug, length 1.8 m [order-no.: 999.0109]

11 Related documents

- Quick guide to STX/ETX protocol
 - Short introduction of basic structure of STX/ETX protocol
- STX/ETX protocol description
 - Detailed description of command structure and available commands for controlling the with a Host system
- SmartRead Manual
 - Description of functionality for stand alone operation
- SmartManager Manual
 - Description for using the SmartManager to configure a for stand alone operation
- C# Demo with source code
 - Example code for integrating the in your own application software

All documents are available for download on www.stt-rfid.com.

12 Contact *sttID*

scemtec Transponder Technology GmbH
Wehrstr. 1
D-51645 Gummersbach

Phone: + 49 (0) 22 61 / 80407 - 0
Fax: + 49 (0) 22 61 / 80407 - 55
e-Mail: info@stt-rfid.com
website: www.stt-rfid.com

If you have any questions about our products, please do not hesitate to call us. Our specialists are always available for you and will provide professional support to find a solution to your specific problem.

13 Document history

Rev.	Changed by	Date	Description
0.1	B. Bröhl	09.05.2022	– Initial preliminary version
			–